

Flansch-Schnellschlussventil

Art. 01-754 G

PN16

quick closing valve spring loaded

Auslösezylinder für pneumatische-,
hydraulische- oder Seilzugbetätigung
Handrad für zusätzliche Absperrung

- Form:** Durchgangsform
- Anschluß:** Flansche gebohrt nach DIN PN16
- Gehäuse:** Stahlguss
- Innenteile:** Edelstahl
- Sitzdichtung:** metallisch
- Temperaturbereich:** -10°C - 140°C
- Anwendungsbereich:** Dampf, Kraftstoffe, Schmieröl,
Kalt- und Warmwasser

*release cylinder for pneumatic-,
hydraulic- and wire-rope operation
handwheel for additional shut-off*

- Form:** straight type
- Connection:** flanges acc. to DIN PN16
- Body:** cast steel
- Inner parts:** stainless steel
- Seat sealing:** metallic
- temperature range:** -10°C - 140°C
- application range:** steam, petrol/fuel oil, lubrication
oil, cold and warm water

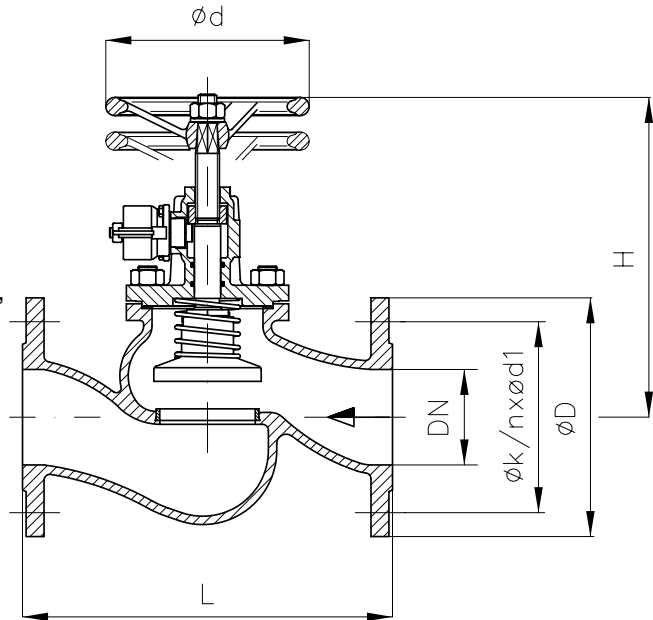

DN	PN	L	H	ød	øD	øk	n x ød1	kg						
15	16	130	165	100	95	65	4 x 14	3,9						
20	16	150	165	100	105	75	4 x 14	4,6						
25	16	160	170	100	115	85	4 x 14	5,4						
32	16	180	175	100	140	100	4 x 18	7,1						
40	16	200	200	160	150	110	4 x 18	9,6						
50	16	230	205	160	165	125	4 x 18	12,5						
65	16	290	240	200	185	145	4 x 18	17,6						
80	16	310	255	200	200	160	8 x 18	21,4						
100	16	350	325	250	220	180	8 x 18	35,7						
125	16	400	350	250	250	210	8 x 18	48,2						
150	16	480	395	315	285	240	8 x 22	72,0						
200	10	600	510	100	340	295	8 x 22	108,0						

Alle Angaben sind unverbindlich und bleiben technischen Änderungen vorbehalten.
All data are not binding and subjected to change without notice.



Fritz Barthel Armaturen GmbH & Co. KG

Schnackenburgallee 16
22525 Hamburg (Germany)

Phone +49 (0) 40 398202-0
Fax +49 (0) 40 398202-77

E-Mail post@barthel-armaturen.de
Internet www.barthel-armaturen.de

09.2016