

Flansch-Druckminderventil

Art. 05-060

PN16

flange pressure reducing valve

Flansche nach DIN PN16

Gehäuse: Grauguss
 Innenteile: Edelstahl
 Sitzdichtung: metallisch
 Temperaturbereich: -10°C - 250°C

flanges acc. to DIN PN16

Body: cast iron
 Inner parts: stainless steel
 Seat sealing: metallic
 temperature range: -10°C - 250°C

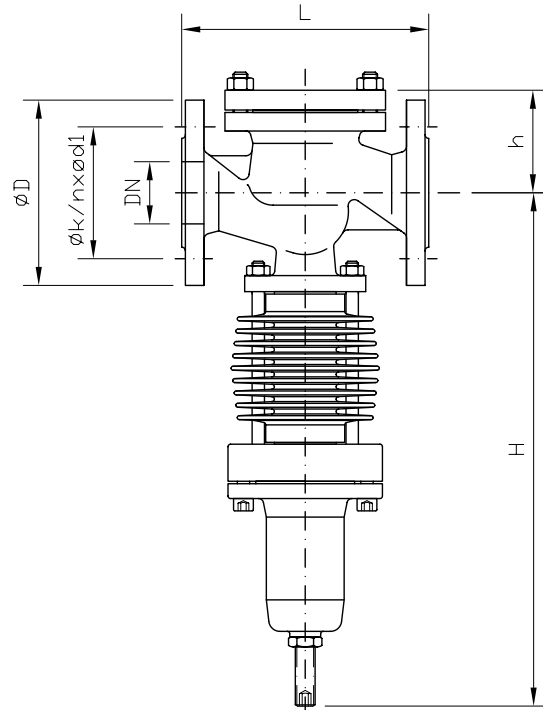

DN	L	h	H	øD	øk	n x ød1	kg				
15	130	90	435	95	65	4 x 14	11,4				
20	150	90	435	105	75	4 x 14	11,4				
25	160	90	435	115	85	4 x 14	12,5				
32	180	120	455	140	100	4 x 18	14,5				
40	200	120	455	150	110	4 x 18	16,0				
50	230	130	605	165	125	4 x 18	35,0				
65	290	155	635	185	145	4 x 18	39,5				
80	310	180	800	200	160	8 x 18	52,5				
100	350	180	825	220	180	8 x 18	68,0				

Alle Angaben sind unverbindlich und bleiben technischen Änderungen vorbehalten.
 All data are not binding and subjected to change without notice.



Fritz Barthel Armaturen GmbH & Co. KG

Schnackenburgallee 16
 22525 Hamburg (Germany)

Phone +49 (0) 40 398202-0
 Fax +49 (0) 40 398202-77

E-Mail post@barthel-armaturen.de
 Internet www.barthel-armaturen.de

06.2010