

DESIGN FEATURES

- Built-in ISO 5211 Direct Mounting Pad Easy Automation
- Fire Safe Design Approved
- Anti-static Devices for Ball-Stem-Body
- Blow-out Proof Stem
- Pressure Balance Hole in Ball Slot
- TA-Luft/ ISO 15848-1 Design Approved
- NACE MR-0175 (Optional)
- Casting Approved by TÜV AD 2000-Merkblatt W0
- Options : 1.Actuator 2.Limit Switch 3.Positioner



APPLICABLE STANDARDS

- Design Standard : EN 12516-1
- Frie Design : API 607 5th 2005, ISO10497
- Face To Face : L-EN 558 Series27
(DIN 3202 F4 DN15~DN100, DIN3202 F5 DN125~DN200)
*L-EN 558 Series1 (DIN 3202 F1)
- Flanged End : EN 1092-1 PN10-40
- Inspection & Testing : EN12266-1

CV VALUE / WEIGHT

DN	CV	Weight (kg)							
		F4 / F5				F1 / F7			
		PN10	PN16	PN25	PN40	PN10	PN16	PN25	PN40
15	18	2.37				2.42			
20	36	3.15				3.23			
25	48	4.09				4.37			
32	93	5.56				5.95			
40	165	6.98				7.81			
50	207	9.67				10.4			
65	450	13.9		14.6		15.5		17.5	
80	780	18.1		20.4		20.1		23.5	
100	1360	25.3		29.5		28.7		35.9	
125	1700	51.0		59.5		—		—	
150	2600	72.5		84.5		—		—	
200	4200	—	120	—	151	—	—	—	—

TORQUE VALUES

Close to Open Torque at Various Differential Pressure (ΔP), Standard Seats (TFM1600&PTFE)

unit : in-lb / N-m

Size/ ΔP	75 psig		150 psig		240 psig / 300 psig		600 psig	
	5 bar		10 bar		16 bar/20 bar		40bar	
DN	N-m	In-lb	N-m	In-lb	N-m	In-lb	N-m	In-lb
15	5	44	5	44	5	44	5	44
20	6	53	6	53	6	53	6	53
25	10	88	10	88	11	97	11	97
32	13	115	13	115	15	133	17	150
40	19	168	19	168	22	195	24	212
50	25	221	29	257	32	283	34	301
65	40	354	45	398	49	434	52	460
80	65	575	72	637	81	717	88	779
100	100	885	110	973	122	1080	132	1168
125	190	1681	210	1858	245	2168	280	2478
150	280	2478	306	2708	340	3009	510	4514
200	370	3274	430	3805	487	4310	730	6461

- Remark : 1. Torques will increase about 30% if seat materials are Reinforced Fiber-Glass PTFE, Carbon-filled. PTFE or EK+PTFE or EK+PTFE or TFM4215.
 2. The torque figures at 5 bar pressure are maximum values to be tested after the valves are placed for 24 hours.
 3. For actuator sizing, a safety factor of minimum 30% is recommended.

TECHNICAL INFORMATION

PRESSURE - TEMPERATURE DATA

The pressure-temperature data of ball valves is determined not only by valve shell materials but also by sealing materials used for ball seats, gland packings and flange gaskets.

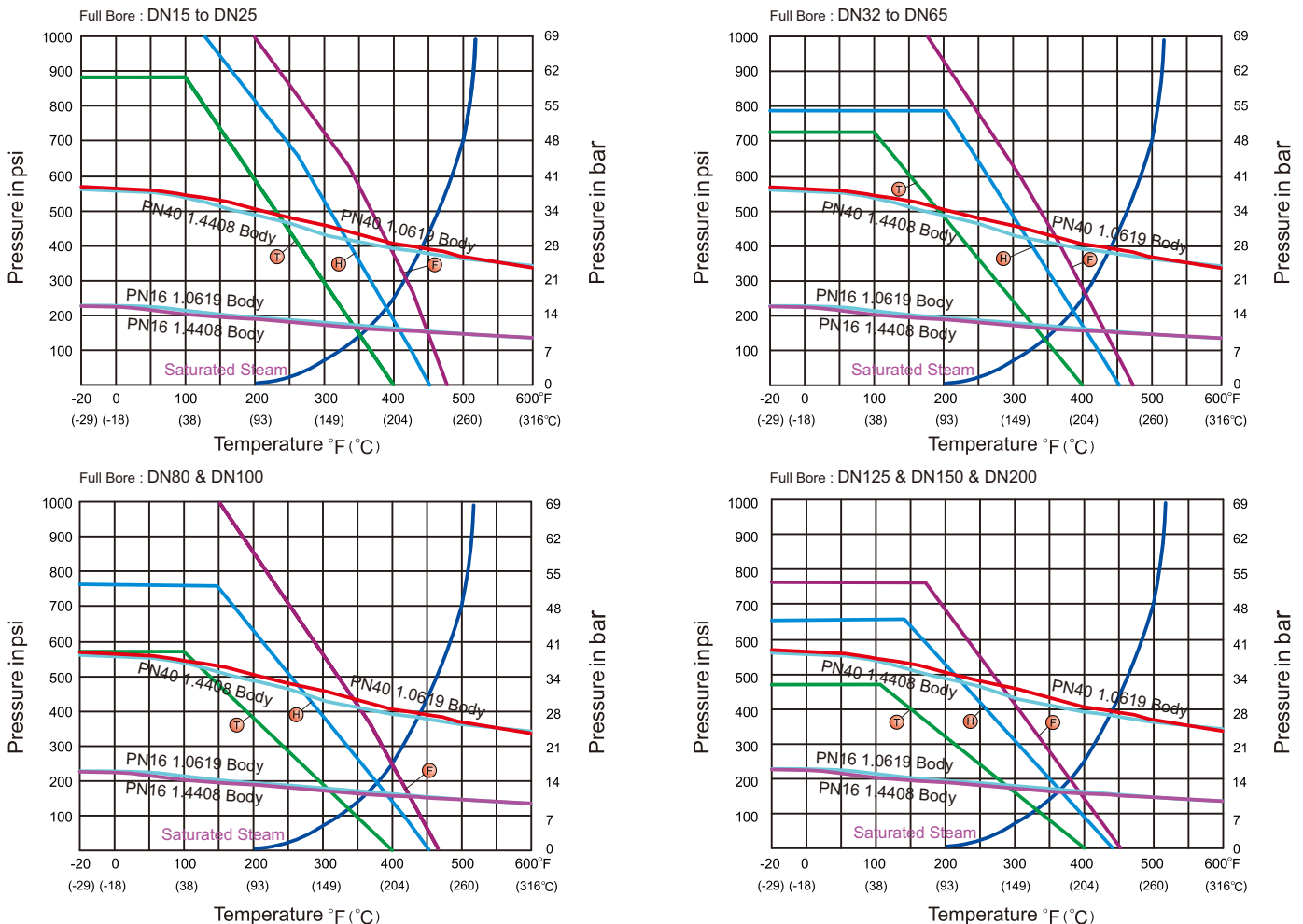

Seat Materials : **T** PTFE **H** TFM1600 **F** TFM4215

Body Ratings: Shown above are for EN10213 Nr. 1.4408 and EN 10213 Nr. 1.0619
 For ratings of other valve shell materials, please refer to the last edition of EN12516-1.

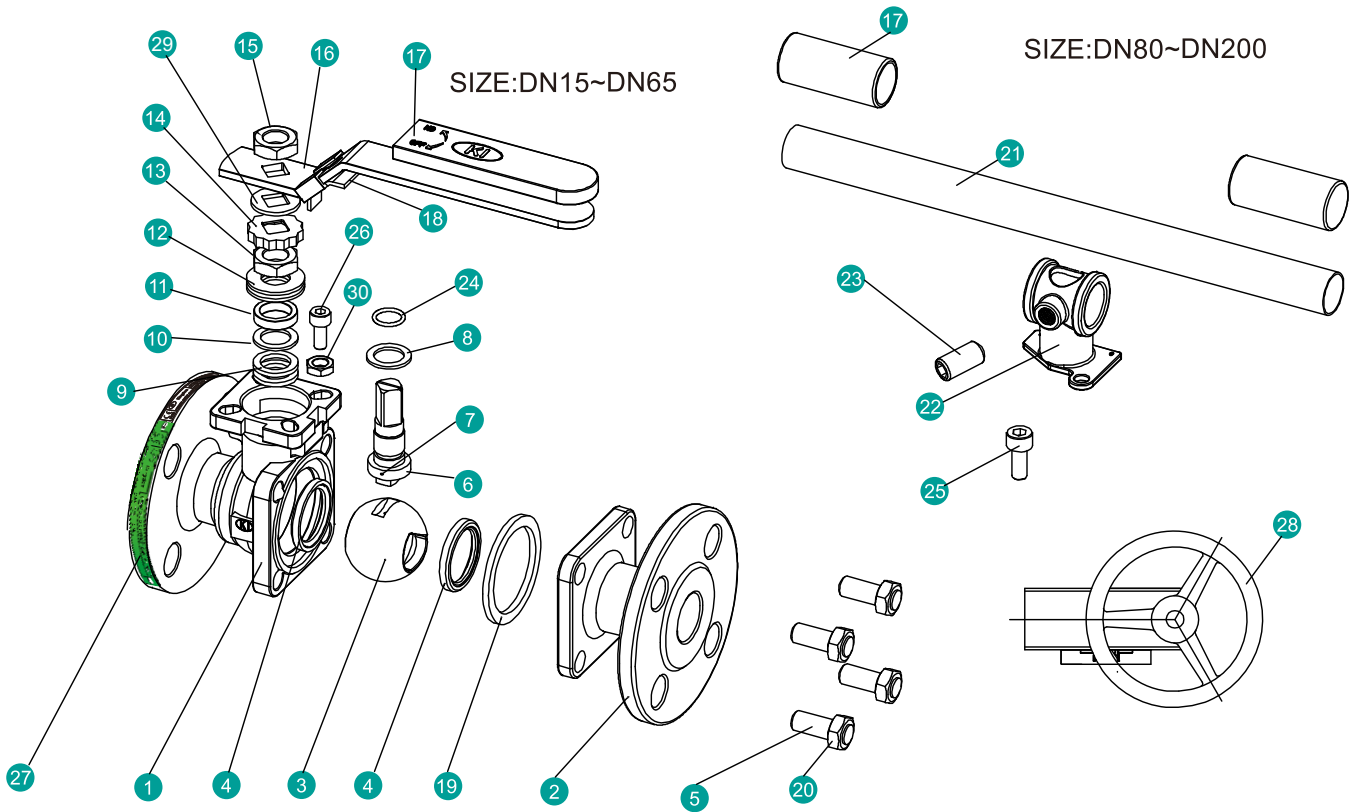

MATERIAL OF CONSTRUCTION

NO.	PART NAME	MATERIALS		
		ANSI	ANSI	ANSI
1	End Cap	1.4408	1.4308	1.0619
2	Body	1.4408	1.4308	1.0619
3	Ball	1.4408	1.4308	
4	Ball Seat	TFM1600 / PTFE /TFM4215		
5	Bolting	A2-70		8.8
6	Stem	316	304	
7	Anti-Static	316	304	
8	Thrust Washer	PTFE/TFM1600		
9	Stem Packing	PTFE / GRAPHITE*		
10	Bushing	50%SS+50%PTFE / 304*		
11	Gland	316		
12	Belleville Washer	301		
13	Stem Nut	A194-8		
14	Stop-lock-Cap	304		
15	Handle Nut (DN15 ~ DN65)	A194-8		
16	Lever (DN15 ~ DN65)	304		
17	Handle Sleeve	304		
18	Lock Device (DN15 ~ DN65)	304		
19	Body Gasket	PTFE / 316 Spiral Wound+GRAPHITE*		
20	Bolt Nut	A2-70	8	
21	Pipe Handle (DN80 ~ DN200)	A53+PLATED Zn		
22	Handle Adapter (DN80 ~ DN200)	A351-CF8		
23	Set Screw (DN80 ~ DN200)	A2-70		
24	O-Ring	FKM (VITON)		
25	Bolting (DN80 ~ DN200)	A2-70		
26	Stop Bolt	A2-70		
27	Nameplate	304		
28	Worm Gear (Optional)	Package		
29	Support Washer	304		
30	Stop Nut	A2-70		

*Materials for 03-512 TAFS (Fire Safe Models)

Direct Mount Pad (ISO 5211)

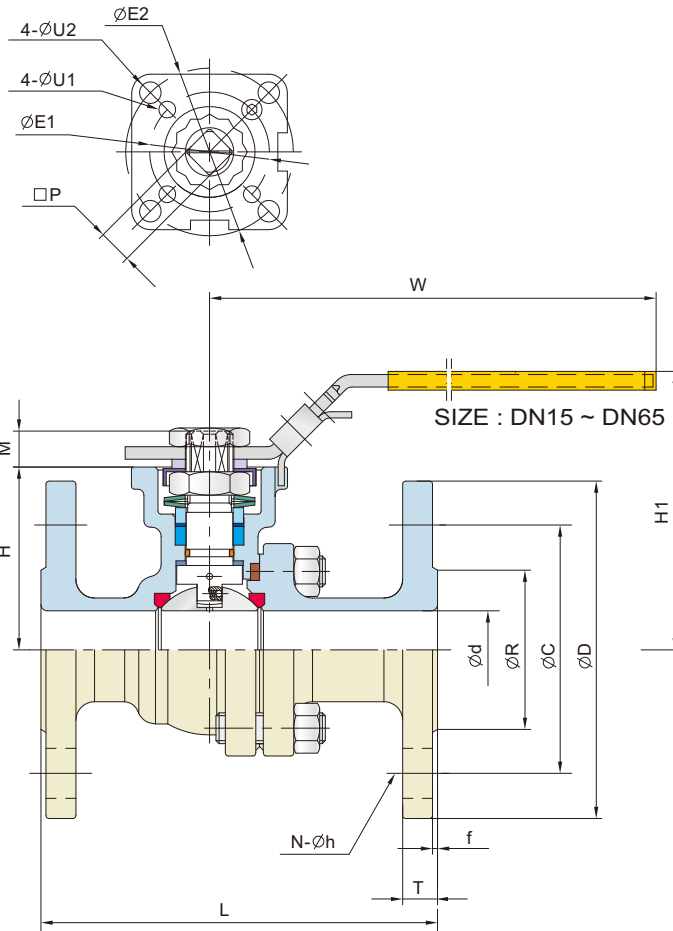

Pipe Handle Operation

SIZE : DN80 ~ DN200

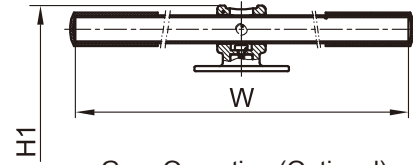

Gear Operation (Optional)

SIZE : DN65 ~ DN200

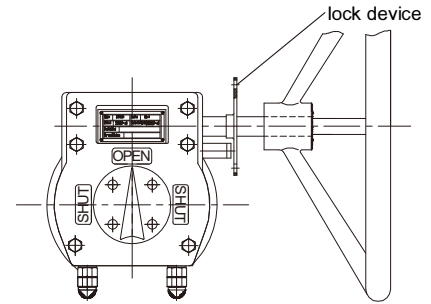

Automation (Optional)

SIZE : DN15 ~ DN200

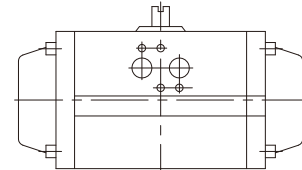

DIMENSION TABLE

EN PN10/16/25/40 (F4 / F5, F1)

Unit : mm

DN	PN	d	L	*L	R	D	C	f	T	N	h	H	H1	W	M	P	U1	U2	E1	E2	ISO 5211	
15	10	15.0	115	130	45	95	65	2	16	4	14	48	78	147	9	9	6	6	36	42	F03-F04	
20	10	20.0	120	150	58	105	75	2	18	4	14	53	84	147	9	9	6	6	36	42	F03-F04	
25	16	25.0	125	160	68	115	85	2	18	4	14	59	90	177	11	11	6	7	42	50	F04-F05	
32	25	32.0	130	180	78	140	100	2	18	4	18	71	102	177	11	11	6	7	42	50	F04-F05	
40	40	38.0	140	200	88	150	110	3	18	4	18	76	110	197	14	14	7	9	50	70	F05-F07	
50	40	50.0	150	230	102	165	125	3	20	4	18	85	118	197	14	14	7	9	50	70	F05-F07	
65	10/16	63.5	170	—	122	185	145	3	18	4	18	102	150	267	17	17	9	11	70	102	F07-F10	
	—		290	22					8	107		155										
80	10/16	76.0	180	310	138	200	160	3	20	8	18	112	176	300	17	17	9	11	70	102	F07-F10	
	24								117			181										
100	10/16	100.0	190	350	158	220	180	3	20	8	18	140	210	400	22	22	—	11	—	102	F10	
	162				235	190	24		22													26
125	10/16	125.0	325	400	188	250	210	3	22	8	18	183	263	600	27	27	14	—	125	—	F12	
	270				220	26	26															
150	10/16	150.0	350	480	212	285	240	3	22	8	18	204	284	800	27	27	14	—	125	—	F12	
	218				300	250	28		26													
200	10	200.0	400	600	268	340	295	3	24	8	12	22	253	334	800	27	27	14	18 ^(a)	125	140 ^(a)	F12orF14 ^(a)
	278				360	310	30		26													
	25				278	360	310		30	26												
	40				285	375	320		34	30												

(a):Optional

L for Series F4 / F5
*L for Series F1