

Flansch-3-Wege-Kompaktkugelhahn

Art. 03-811

PN16

flange-3-way-compact ball valve

Flansche gebohrt nach DIN PN16

Gehäuse: Stahl
 Innenteile: Edelstahl
 Sitzdichtung: PTFE
 Temperaturbereich: -20°C - 200°C

flanges acc. to DIN PN16

Body: steel
 Inner parts: stainless steel
 Seat sealing: PTFE
 temperature range: -20°C - 200°C

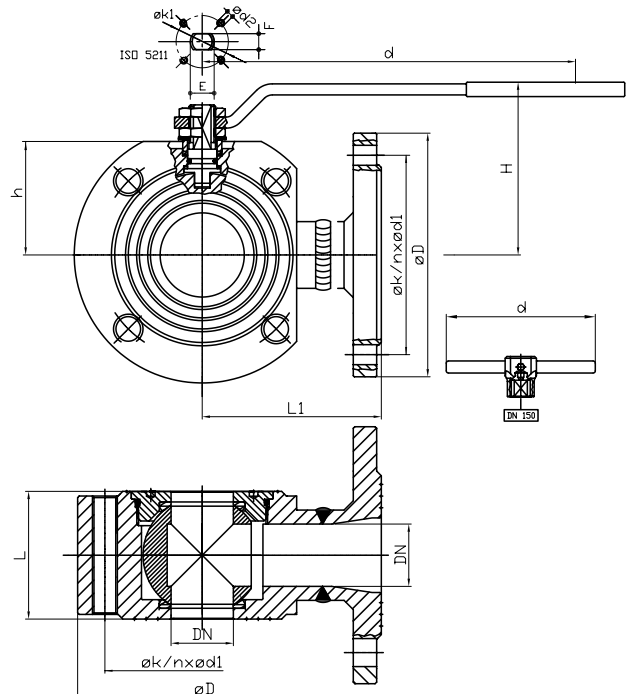

DN	L	L1	H	h	øD	øk	n x M	n x M	E/F	øk1	kg
15	40	76	64,5	47	95	65	4 x M12	4 x M12	10/7	32	2,23
20	40	82	67	49,5	105	75	4 x M12	4 x M12	10/7	32	2,86
25	46	86	79	59	115	85	4 x M12	4 x M12	12/8	42 F04	3,89
32	58	100	84	64	140	100	4 x M16	4 x M16	12/8	42 F04	6,21
40	71	105	102,5	78	150	110	4 x M16	4 x M16	16/10	50 F05	8,5
50	82	115	109	85	165	125	4 x M16	4 x M16	16/10	50 F05	12,27
65	106	125	128	104,5	185	145	4 x M16	4 x M16	20/14	70 F07	19,1
80	122	150	136,5	113	200	160	8 x M16	8 x M16	20/14	70 F07	24,34
100	152	159	155,5	136	220	180	8 x M16	8 x M16	24/18	102 F10	38,45

Alle Angaben sind unverbindlich und bleiben technischen Änderungen vorbehalten.
 All data are not binding and subjected to change without notice.



Fritz Barthel Armaturen GmbH & Co. KG

Schnackenburgallee 16
 22525 Hamburg (Germany)

Phone +49 (0) 40 398202-0
 Fax +49 (0) 40 398202-77

E-Mail post@barthel-armaturen.de
 Internet www.barthel-armaturen.de

06.2010