

Flansch-3-Wege-Kompaktkugelhahn

Art. 03-813

PN16

flange-3-way-compact ball valve

Flansche geb. nach DIN EN 1092 PN16

Gehäuse: Edelstahl
 Innenteile: Edelstahl
 Sitzdichtung: PTFE
 Temperaturbereich: -20°C - 200°C

flanges acc. to DIN EN 1092 PN16

Body: stainless steel
 Inner parts: stainless steel
 Seat sealing: PTFE
 temperature range: -20°C - 200°C

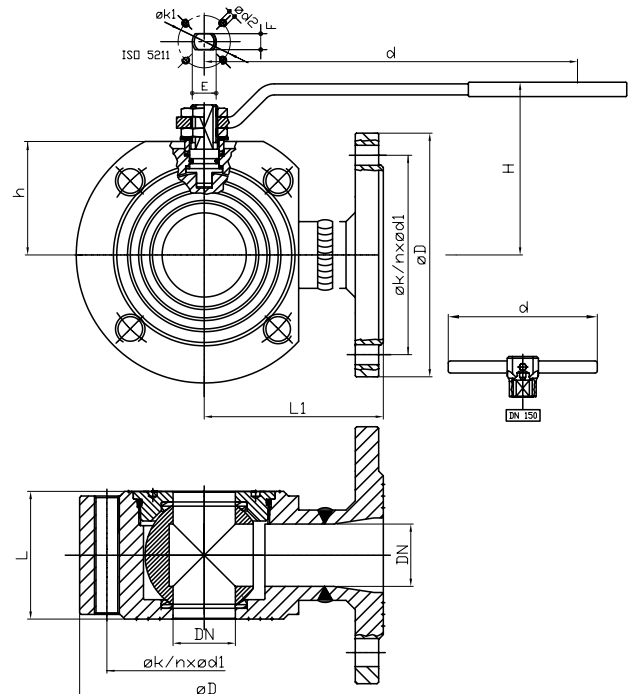

| DN | L | L1 | H | h | øD | øk | n x ød1 | n x M | E/F | øk1 | kg |
|-----|-----|-----|-------|-------|-----|-----|---------|---------|-------|---------|-------|
| 15 | 40 | 76 | 64,5 | 47 | 95 | 65 | 4 x 14 | 4 x M12 | 10/7 | 32 | 2,23 |
| 20 | 40 | 82 | 67 | 49,5 | 105 | 75 | 4 x 14 | 4 x M12 | 10/7 | 32 | 2,86 |
| 25 | 46 | 86 | 79 | 59 | 115 | 85 | 4 x 14 | 4 x M12 | 12/8 | 42 F04 | 3,89 |
| 32 | 58 | 100 | 84 | 64 | 140 | 100 | 4 x 18 | 4 x M16 | 12/8 | 42 F04 | 6,21 |
| 40 | 71 | 105 | 102,5 | 78 | 150 | 110 | 4 x 18 | 4 x M16 | 16/10 | 50 F05 | 8,5 |
| 50 | 82 | 115 | 109 | 85 | 165 | 125 | 4 x 18 | 4 x M16 | 16/10 | 50 F05 | 12,27 |
| 65 | 106 | 125 | 128 | 104,5 | 185 | 145 | 4 x 18 | 4 x M16 | 20/14 | 70 F07 | 19,1 |
| 80 | 122 | 150 | 136,5 | 113 | 200 | 160 | 8 x 18 | 8 x M16 | 20/14 | 70 F07 | 24,34 |
| 100 | 152 | 159 | 155,5 | 136 | 220 | 180 | 8 x 18 | 8 x M16 | 24/18 | 102 F10 | 38,45 |

Alle Angaben sind unverbindlich und bleiben technischen Änderungen vorbehalten.
 All data are not binding and subjected to change without notice.



Fritz Barthel Armaturen GmbH & Co. KG

Schnackenburgallee 16
 22525 Hamburg (Germany)

Phone +49 (0) 40 398202-0
 Fax +49 (0) 40 398202-77

E-Mail post@barthel-armaturen.de
 Internet www.barthel-armaturen.de

06.2010