

Mittelflansch-Absperrklappe

Art. 04-026.1NK3

PN10

mono-flange butterfly valve

geteilte Welle
 Schneckenradgetriebe
Form: Durchgangsform
Baulänge: ISO 5752 Reihe 16 (K3)
Anschluß: Flansche geb. nach DIN PN10/ PN16
Gehäuse: Sphäroguss (GGG40.3)
Innenteile: Aluminiumbronze (C95400)
Sitzdichtung: NBR
Temperaturbereich: -10°C - 80°C
Anwendungsbereich: neutrale Gase, Seewasser, Kalt- und Warmwasser

splitted shaft
 worm gear
Form: straight type
Face to face: ISO 5752 Series 16
Connection: flanges acc. to DIN PN10/ PN16
Body: nodular cast iron (GGG40.3)
Inner parts: aluminium bronze (C95400)
Seat sealing: NBR
temperature range: -10°C - 80°C
application range: neutral gases, seawater, cold and warm water

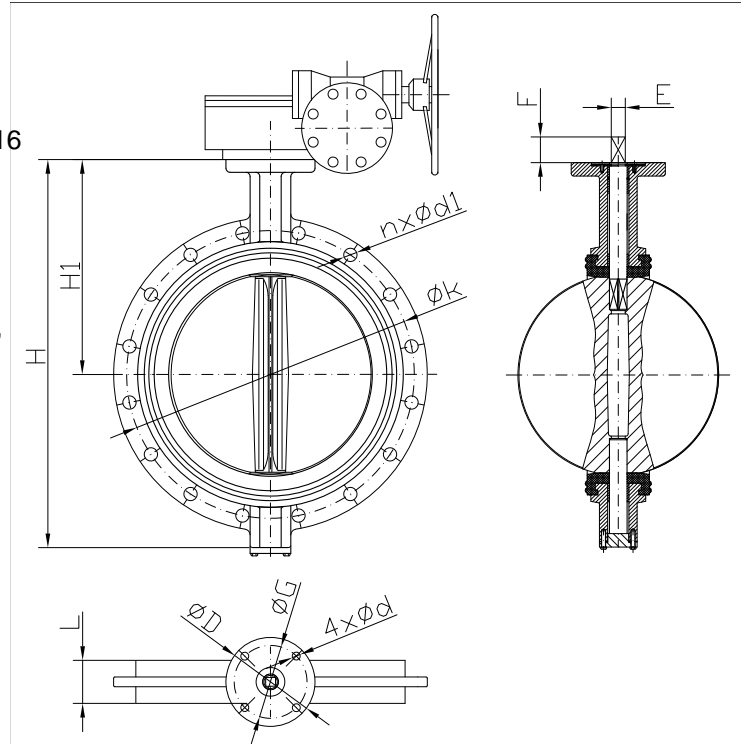

DN	L	H	H1	øk	n x ød1	øD	øG	4 x ød	ISO 5211	E	F			
50	43	220	140	125	4 x ø19	90	70	4 x ø10	F07	11 x 11	32			
65	46	239	150	145	4 x ø19	90	70	4 x ø10	F07	11 x 11	32			
80	64	253	158	160	8 x ø19	90	70	4 x ø10	F07	11 x 11	32			
100	65		176	180	8 x ø19	90	70	4 x ø10	F07	11 x 11	32			
125	70	317	190	210	8 x ø19	90	70	4 x ø10	F07	14 x 14	32			
150	76	362	212	240	8 x ø23	90	70	4 x ø10	F07	14 x 14	32			
200	89	414	235	295	8 x ø23	125	102	4 x ø12	F10	17 x 17	45			
250	114	473	265	350	12 x ø23	125	102	4 x ø12	F10	22 x 22	45			
300	114	547	305	400	12 x ø23	125	102	4 x ø12	F10	22 x 22	50			
350	127	638	368	460	16 x ø23	150	125	4 x ø14	F12	22 x 22	50			
400	140	710	400	515	16 x ø28	175	140	4 x ø18	F14	27 x 27	50			
450	152	762	422	565	20 x ø28	175	140	4 x ø18	F14	27 x 27	50			
500	152	787	410	620	20 x ø28	175	140	4 x ø18	F14	36 x 36	60			

Andere Ausführungen:
 Art.-Nr. 04-026.1EK3 EPDM-Manschette
 Art.-Nr. 04-026.1VK3 FPM-Manschette
 Andere Flanschanschlüsse und Betätigungen auf Anfrage.

other types:
 art.-no. 04-026.1EK3 EPDM seat
 art.-no. 04-026.1VK3 FPM seat
 other flange connections and actuation on request.

Alle Angaben sind unverbindlich und bleiben technischen Änderungen vorbehalten.
 All data are not binding and subjected to change without notice.



Fritz Barthel Armaturen GmbH & Co. KG

Schnackenburgallee 16
 22525 Hamburg (Germany)

Phone +49 (0) 40 398202-0
 Fax +49 (0) 40 398202-77

E-Mail post@barthel-armaturen.de
 Internet www.barthel-armaturen.de

09.2016