

# 3-way Control Valve type M3F

Cast iron, PN 10, DN 80 – 150 mm

0-2.3.09-J

Page 1 of 2

## APPLICATIONS

Control valves type M3F are designed for regulating of water, lubricating oil and other liquid media and can be mounted in the pipe system as either mixing or diverting valves. However when mounting as a diverting valve the pressure drop is increased, compared with mounting as a mixing valve. See "Important note" under Technical Data. The valves are used in conjunction with our temperature regulators for controlling industrial processes, district and central heating plants and marine installations.

## DESIGN

The valve components - seats and cone are made of alu bronze, the spindle is made of stainless steel. The valve body is made of cast iron EN-GJS-400-15 with flanges drilled according to EN 1092-2. The connection thread for the actuator is G1B ISO 228. The valves have two balanced single seats. The leakage rate is less than 0.5% of the full flow (according to VDI/VDE 2174). Tight between port 1(AB) og 3(B) is optional.

## FUNCTION

Without an actuator being installed, connection A-AB is fully open and connection B-AB completely closed, by means of a spring. By increasing pressure on the spindle, the opening of the ports changes proportionally to the travel of the spindle, and when the spindle is pressed to the bottom, connection B-AB is fully open and connection A-AB completely closed.



## TECHNICAL DATA

### Materials:

- Valve body	Cast iron EN-GJS-400-15
- Seats and cone	Alu Bronze CuAL10Fe5Ni5
- Spindle	Stainless steel
- O-ring	90 NBR
- Gasket	Reinz-AFM34

Seating	Two balanced single seats
---------	------------------------------

Flow characteristic	Almost linear
---------------------	---------------

Leakage rate	≤ 0.5% of Kvs
--------------	---------------

Regulating capability	Kvs/Kvr > 25
-----------------------	--------------

Flanges drilled according to	EN 1092-2 PN 10
------------------------------	-----------------

Counter flanges	DIN 2632
-----------------	----------

Nominal pressure	PN 10 (10 bar/max 120°C, option 9 bar/max 160 °C)
------------------	--

For regulating of process and central heating plants

### Important note

In case the valves are applied as diverting valves, the pressure drop will increase by 35% and the kvs-value will decrease by 14% as against mixing valves.

Subject to change without notice.

## FEATURES

- Can be used for both mixing and diverting
- Simple design secures reliable controls and reduces costly downtime.
- Location of the pack box in the actuator makes the valve service friendly

## PRESSURE/TEMPERATURE DIAGRAM

According to DIN 2401

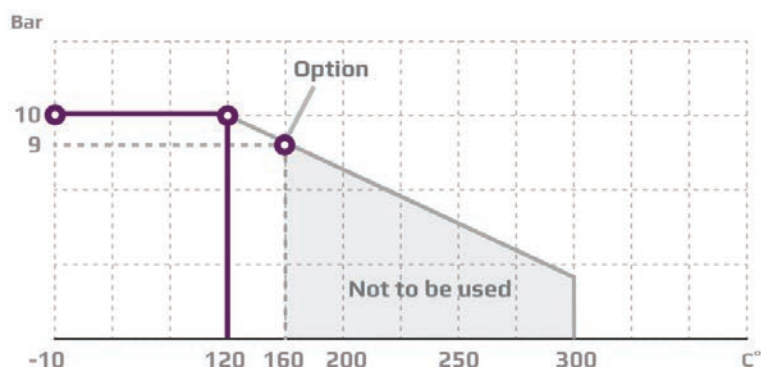

### PORT NUMBERING

The ports of valves type M3F are marked with the letters AB, A and B.

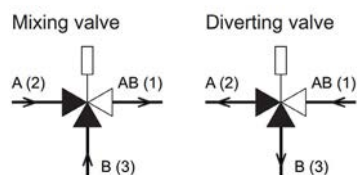

Port AB(1)  
Port A(2)  
Port B(3)

common port always open  
closes at load on spindle  
opens at load on spindle



### MOUNTING

The valve can be installed with vertical as well as horizontal spindles. The valve must be mounted in a way that the valve actuator will be exposed to a minimum of moisture and unnecessary vibrations.

### DIMENSION SKETCH

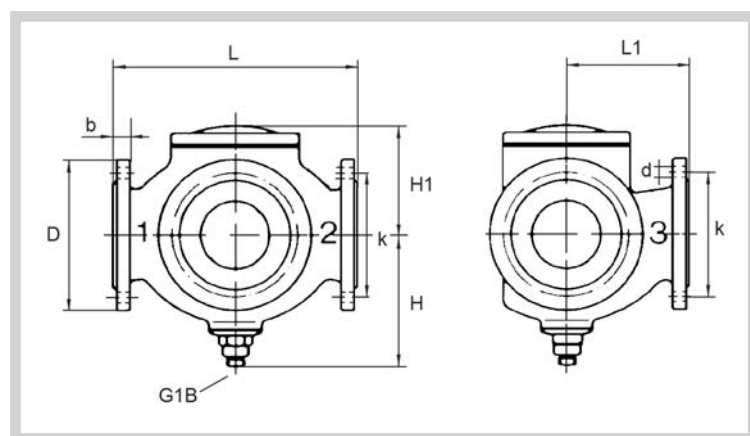

Type	L mm	L1 mm	H mm	H1 mm	D (dia.) mm	b mm	k (dia.) mm	d mm dia. (number)
80 M3F	310	155	180	127	200	20	160	18x(8)
100 M3F	350	175	195	141	220	22	180	18x(8)
125 M3F	400	240	245	171	250	24	210	18x(8)
150 M3F	480	270	280	189	285	24	240	22x(8)

### SPECIFICATIONS

Type	Flange connection DN in mm	Opening mm	Mixing valve $k_{vs}$ -value $m^3/h$	Divertng valve $k_{vs}$ -value $m^3/h$	Lifting height mm	Weight kg
80 M3F	80	80	80	69	11	35
100 M3F	100	100	125	108	13	44
125 M3F	125	125	215	185	18	72
150 M3F	150	150	310	267	20	111